

# **POWERMATIC®**

## **Operating Instructions and Parts Manual 15-inch Variable Speed Drill Press Model PM2815BT**



**Powermatic**  
427 New Sanford Road  
LaVergne, Tennessee 37086  
Ph.: 800-274-6848  
[www.powermatic.com](http://www.powermatic.com)

**Part No. M-PM1-34**  
Edition 1 08/2023  
Copyright © 2023 Powermatic



## 1.0 IMPORTANT SAFETY INSTRUCTIONS

### Warning – To reduce risk of injury:

1. Read and understand the entire owner's manual before attempting assembly or operation.
2. Read and understand the warnings posted on the machine and in this manual. Failure to comply with all these warnings may cause serious injury.
3. Replace the warning labels if they become obscured or removed.
4. This drill press is designed and intended for use by properly trained and experienced personnel only. If you are not familiar with the proper and safe operation of a drill press, do not use until proper training and knowledge have been obtained.
5. Do not use this drill press for other than its intended use. If used for other purposes, Powermatic disclaims any real or implied warranty and holds itself harmless from any injury that may result from that use.
6. Always wear approved safety glasses/face shields while using machine. Everyday eyeglasses only have impact resistant lenses; they are not safety glasses.
7. Before operating this drill press, remove tie, rings, watches and other jewelry, and roll sleeves up past the elbows. Remove all loose clothing and confine long hair. Non-slip footwear or anti-skid floor strips are recommended. Do not wear gloves.
8. Wear ear protectors (plugs or muffs) during extended periods of operation
9. Do not operate this machine while tired or under the influence of drugs, alcohol or any medication.
10. Make certain the switch is in the OFF position before connecting the machine to the power supply.
11. Make certain the machine is properly grounded.
12. Make all machine adjustments or maintenance with the machine unplugged from the power source.
13. Remove adjusting keys and wrenches. Form a habit of checking to see that keys and adjusting wrenches are removed from the machine before turning it on.
14. Always keep safety guards in place when the machine is in use. If removed for maintenance purposes, use extreme caution, and replace the guards immediately after completion of maintenance.
15. Check damaged parts. Before further use of the machine, a guard or other part that is damaged should be carefully checked to determine that it will operate properly and perform its intended function. Check for alignment of moving parts, binding of moving parts, breakage of parts, mounting and any other conditions that may affect its operation. A guard or other part that is damaged should be properly repaired or replaced.
16. Provide for adequate space surrounding work area and non-glare, overhead lighting.
17. Keep the floor around the machine clean and free of scrap material, oil and grease.
18. Keep visitors a safe distance from the work area. **Keep children away.**
19. Make your workshop child proof with padlocks, master switches or by removing starter keys.
20. Give your work undivided attention. Looking around, carrying on a conversation and "horseplay" are careless acts that can result in serious injury.
21. Always maintain a balanced stance so that you do not fall into the blade or other moving parts. Do not overreach or use excessive force to perform any machine operation.
22. Use the right tool at the correct speed and feed rate. Do not force a tool or attachment to do a job for which it was not designed. The right tool will do the job better and more safely.
23. Use recommended accessories; improper accessories may be hazardous.
24. Maintain tools with care. Keep drill bits sharp and clean for the best and safest performance. Follow instructions for lubricating and changing accessories.
25. Turn off machine and disconnect from power before cleaning. Use a brush to remove chips or debris — do not use bare hands.
26. Do not stand on the machine. Serious injury could occur if the machine tips over.
27. Never leave machine running unattended. Turn the power off and do not leave the machine until spindle comes to a complete stop.
28. Remove loose items and unnecessary work pieces from the area before starting the machine.
29. Don't use in dangerous environment. Don't use power tools in damp or wet location or expose them to rain. Keep work area well lighted.

## SAVE THESE INSTRUCTIONS

Familiarize yourself with the following safety notices used in this manual:

**⚠CAUTION** This means that if precautions are not heeded, it may result in minor injury and/or possible machine damage.

**⚠WARNING** This means that if precautions are not heeded, it may result in serious injury or possibly even death.

## 2.0 About This Manual

This manual is provided by Powermatic covering the safe operation and maintenance procedures for a Powermatic Model PM2815BT Drill Press. This manual contains instructions on installation, safety precautions, general operating procedures, maintenance instructions and parts breakdown. Your machine has been designed and constructed to provide consistent, long-term operation if used in accordance with the instructions as set forth in this document.

If there are questions or comments, please contact your local supplier or Powermatic. Powermatic can also be reached at our web site: [www.powermatic.com](http://www.powermatic.com).

Retain this manual for future reference. If the machine transfers ownership, the manual should accompany it.

** **WARNING**** Read and understand the entire contents of this manual before attempting assembly or operation. Failure to comply may cause serious injury.

Record your purchase information here for quick reference:

Stock no.:
Model no.:
Date of purchase:
Place of purchase:

## 3.0 Table of Contents

Section	Page
1.0 IMPORTANT SAFETY INSTRUCTIONS .....	2
2.0 About This Manual .....	4
3.0 Table of Contents .....	5
4.0 Specifications .....	6
4.1 Base Hole Centers .....	7
5.0 Unpacking .....	8
5.1 Shipping Contents .....	8
5.2 Cleanup .....	8
6.0 Assembly .....	9
6.1 Tools Required for Assembly .....	9
6.2 Procedure .....	9
7.0 Electrical Connections .....	12
7.1 Grounding Instructions .....	12
7.2 Extension Cords .....	12
8.0 Adjustments .....	12
8.1 Table Movement .....	12
8.2 Chuck and Arbor Removal .....	13
8.3 Depth Stop .....	13
8.4 Quill Retraction Lock .....	14
8.5 Laser Adjustment .....	14
8.6 LED Light .....	15
9.0 Operating Controls .....	15
10.0 Operation .....	15
10.1 Installing Bits .....	15
10.2 Positioning Work Piece .....	15
10.3 General Inspection .....	16
10.4 Speed Setting .....	16
11.0 User-Maintenance .....	16
12.0 Troubleshooting the PM2815BT Drill Press .....	17
12.1 Mechanical and Electrical .....	17
12.2 Error Codes on Digital Readout .....	18
13.0 Replacement Parts .....	19
13.1.1 PM2815BT Gear Box Assembly – Exploded View .....	20
13.1.2 PM2815BT Gear Box Assembly – Parts List .....	21
13.2.1 PM2815BT Quill and Laser Assembly – Exploded View .....	22
13.2.2 PM2815BT Quill and Laser Assembly – Parts List .....	23
13.3.1 PM2815BT Control Panel – Exploded View .....	24
13.3.2 PM2815BT Control Panel – Parts List .....	24
13.4.1 PM2815BT Top Cover & PCB Assembly – Exploded View .....	25
13.4.2 PM2815BT Top Cover & PCB Assembly – Parts List .....	25
13.5.1 PM2815BT Work Table Assembly – Exploded View .....	26
13.5.2 PM2815BT Work Table Assembly – Parts List .....	27
13.6.1 PM2815BT Column Assembly – Exploded View .....	28
13.6.2 PM2815BT Column Assembly – Parts List .....	28
14.0 Optional accessories .....	29
15.0 Electrical Connections for PM2815BT Drill Press .....	30
16.0 Warranty and Service .....	31

## 4.0 Specifications

Model number	<b>PM2815BT</b>
Stock number	<b>PM1-34</b>
<b>Motor and electrical</b>	
Motor type	brushed DC
Horsepower	3/4HP
Phase	Single
Voltage	120V
Cycle	60Hz
Listed FLA (full load amps)	11.6 A
Main on/off switch	manual push button, with safety key and power indicator lamp
Power transfer	Gears
Power cord	14 AWG, 6-1/2 ft. (198 cm)
Power plug included	15 amp
Recommended circuit size <sup>1</sup>	20A for 115V
Laser	Yes
Work lamp	LED
<b>Head and Capacities</b>	
Swing	15" (381mm)
Chuck style and shank capacity	Keyed / MT2-JT3, 5/8 in. (16 mm)
Quill travel	5"
Scale display	4" (spindle travel per one revolution of handle)
Depth setting	3.7"
Quill diameter	2.04" (52 mm)
Speed range (RPM)	250 - 3000
Maximum spindle to table distance	18.5" (470 mm)
Minimum spindle to table distance	1.77" (100 mm)
Maximum chuck to table distance	11.02" (280 mm)
Maximum spindle to base distance	22.83" (580 mm)
Maximum chuck to base distance	18.464" (469 mm)
Readout	Digital
Speed Selection	Dial
<b>Table</b>	
Table size, L x W	12.59" x 11.614 (320 mm x 295 mm)
Table tilt	0 to 90 deg. L and R
Table rotation around column	360 deg.
Table insert	3.7" x 3.9" (94 mm x 99 mm x 11mm)
<b>Base and Column</b>	
Base size, L x W x H	17.9" x 11.74" x 2.28" (455 mm x 298.2 mm x 58 mm)
Column diameter	2.87 in. (73 mm)
<b>Main materials</b>	
Head	cast iron
Table	cast iron
Column	steel
Base	cast iron
<b>Main dimensions</b>	
Overall dimensions assembled, LxWxH (approx.)	14.17 x 23.22 x 47.24 in. (360 x 590 x 1200 mm)
Shipping dimensions, LxWxH (approx.)	45.47 x 21.65 x 14.37 in. (1155 x 550 x 365 mm)
<b>Weights</b>	
Net weight (approx.)	138.47 lbs. (62.94 kg)
Shipping weight (approx.)	152.11 lbs. (69.14 kg)

<sup>1</sup> subject to local/national electrical codes

<sup>2</sup> The specified values are emission levels and are not necessarily to be seen as safe operating levels. As workplace conditions vary, this information is intended to allow the user to make a better estimation of the hazards and risks involved only.

L = length, W = width, H = height

The specifications in this manual were current at time of publication, but because of our policy of continuous improvement, Powermatic reserves the right to change specifications at any time and without prior notice, without incurring obligations.

4.1 Base Hole Centers

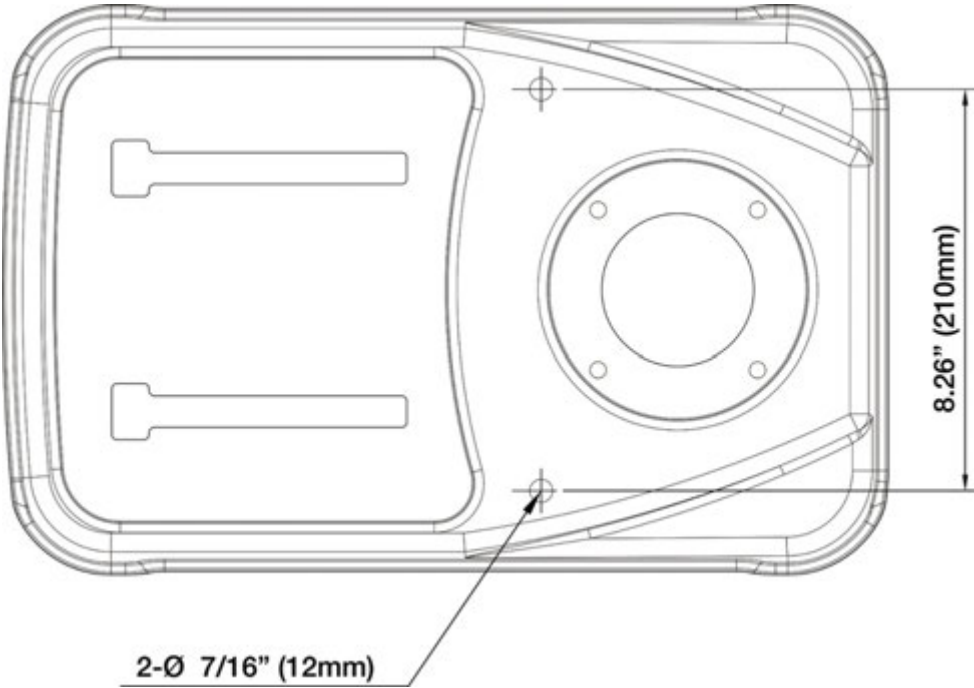

Figure 4-1: Hole Centers

**⚠ WARNING** Read and understand the entire contents of this manual before attempting assembly or operation. Failure to comply may cause serious injury.

## 5.0 Unpacking

Remove all smaller items (Figure 5-2) from shipping carton. Lift off upper Styrofoam packing to expose the larger components (Figure 5-1). The base is underneath the table.

Remove table and base in preparation for assembly.

Inspect all contents for shipping damage – if any damage is identified, report it to your distributor and shipping agent.

If any parts are missing, contact your distributor or Powermatic. (Check machine first to see if any parts were pre-assembled.)

Do not discard carton or packing material until drill press is assembled and running satisfactorily.

### 5.1 Shipping Contents

Qty.	Description	Item
1	Drill press head assembly	A
1	Column assembly	B
1	Base	C
1	Table assembly	D
4	Socket head cap screws & lock washers	E
1	Chuck key	F
1	Crank handle	G
1	Drift key	H
1	Worm drive	J
3	Turret handles	K
1	Keyed chuck	L
1	Arbor	M
1	Owner's manual	
1	Product registration card	

Table 1

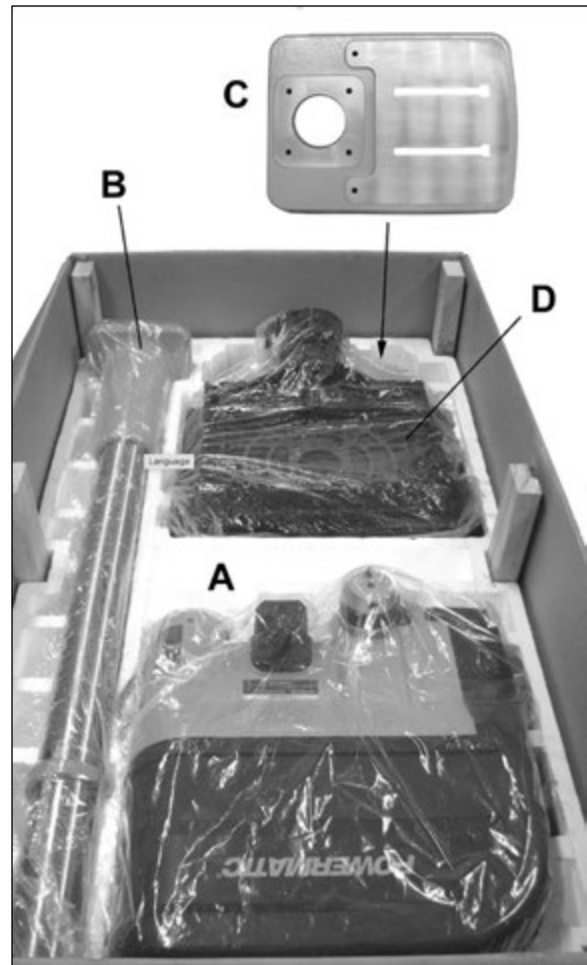

Figure 5-1

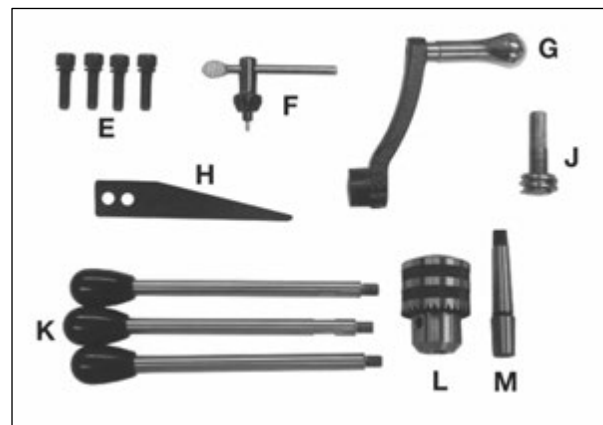

Figure 5-2

### 5.2 Cleanup

Exposed metal surfaces on the drill press have been factory-coated with a rust protectant. Remove this with a soft rag moistened with a light solvent, such as mineral spirits. Do not use an abrasive pad as this may scratch surfaces, and do not use gasoline, paint thinner or acetone, as these will damage plastic components and painted surfaces.



## 6.0 Assembly

The drill press should be placed in a dry area, with a level floor and good lighting. Provide enough space around machine to allow for operations and any adjustments or servicing.

### 6.1 Tools Required for Assembly

3 mm & 5 mm hex wrenches (provided)  
10 mm hex wrench (not provided)  
Rubber mallet (or hammer and wood block)

Additional tools may be needed for certain adjustments.

### 6.2 Procedure

**⚠ WARNING** Larger components are very heavy; Multiple assistants are mandatory for assembly. Failure to comply may cause serious injury and/or machine damage.

1. Set base on a level, stable floor.
2. Set the column onto the base as shown in Figure 6-1. Align the four threaded mounting holes on the column mounting flange with the four threaded mounting holes on the base. Using 8 mm hex wrench, screw four socket head cap screws with washers through the column mounting flange and into the base. Tighten all screws firmly.



Figure 6-1

3. The base may be secured to floor with lag screws (not provided) through two holes in the base. Refer to Figure 4-1 for hole spacing.

NOTE: If you do not wish permanent attachment to the floor, the drill press can be bolted to a plywood panel which will serve as an expanded base and further stabilize the machine. Use a high grade of plywood at least 3/4" thick. It should be large enough to prevent

vibration, sliding or moving of drill press during operation. Do not use a mobile base with this machine.

4. Insert shaft of worm drive (R, Figure 6-2) through table bracket hole, while meshing worm drive with the preinstalled gear.

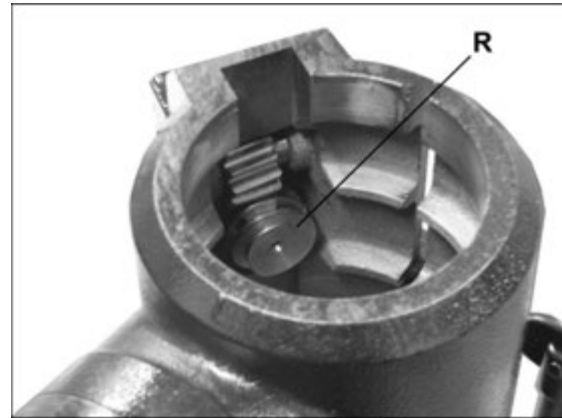

Figure 6-2

5. Remove collar (T<sub>1</sub>) and rack (T<sub>2</sub>) from column. See Figure 6-3.



Figure 6-3

6. Insert rack (Figure 6-4) into slot in table bracket, meshing the rack teeth with the worm gear. NOTE: The longer un-toothed section of the rack is toward the top.
7. Hold the rack in the slot, while setting the table bracket over the column. Then slide table bracket and rack together down the column.

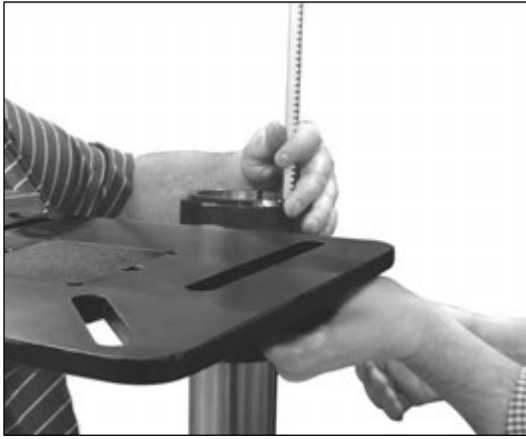

Figure 6-4

8. The lower end of the rack should rest in the lip of the column holder.
9. Place collar onto column and slide it down over top edge of rack. Tighten set screw on collar (Figure 6-5).

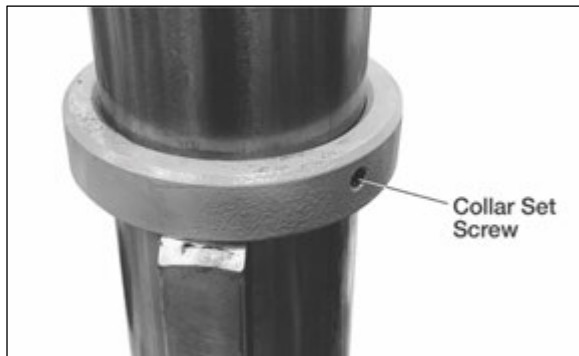

Figure 6-5

10. Slide crank handle (P) onto protruding shaft of worm and tighten set screw in handle with a 3mm hex wrench (Figure 6-6).



Figure 6-6

### 6.2.1 Drill Head Mounting

**CAUTION** Drill head is heavy. Hoist or forklift is the preferred method of lifting. If these are not available, use minimum 2 persons to lift.

If lifting with hoist/forklift, see Figure 6-7 thru 6-9.

1. Prepare a solid wood block, about 16" L x 4" W x 2.5" t. Drill a 3-inch hole through center of

block, and through-holes near each end to accept eye bolts with fasteners, as shown.

2. Place this block onto main spindle, run straps through the eyebolts, and another strap toward the rear of head as shown in Figure 6-9.
3. Carefully lift head and place on column.

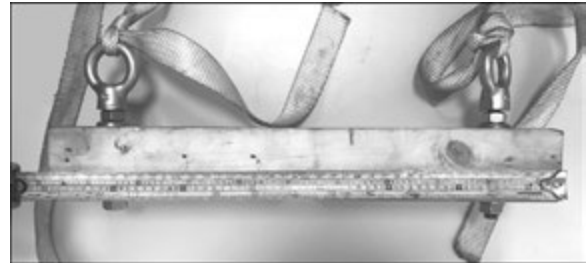

Figure 6-7

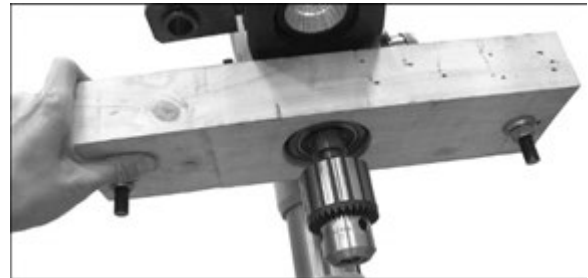

Figure 6-8



Figure 6-9

If lifting by hand:

1. Loosen table lock handle (Figure 6-10) and turn crank handle counterclockwise to lower table to a convenient position near the head and tighten the locking handle. Place cardboard pieces atop the table to protect the surface.



Figure 6-10

2. Cut the corners of the shipping box and fold down the cardboard sides to better expose the drill head (Figure 6-11). Trim away excess to prevent a potential tripping hazard.



Figure 6-11

3. Carefully lift head and place on table. Orient head to correct mounting position.
4. Turn crank handle to raise head to highest point on column. NOTE: Stabilize head and lift beneath table to lessen the weight upon table and allow easier cranking.
5. Lift head and place on column.

*Continue assembly as follows:*

1. Adjust head parallel to base and tighten two (2) set screws (Figure 6-12).

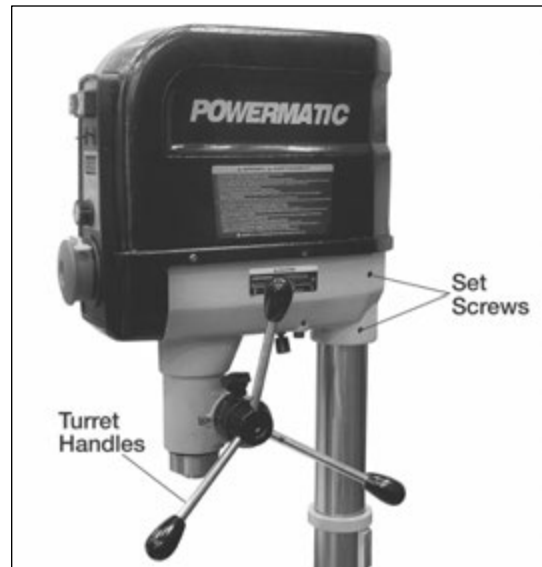

Figure 6-12

2. Install three turret handles into hub on the side of drill head (Figure 6-12). Screw them in completely; use a wrench on the shaft flats to tighten.

### 6.2.2 Arbor and Chuck

1. Thoroughly clean entire arbor and inside of chuck (Figure 6-13) with a soft rag and solvent, such as mineral spirits. Any grease or residue in these areas can cause the pieces to separate, creating a safety hazard and potential damage to the tool.



Figure 6-13

2. Slide arbor up into spindle.
3. Firmly push chuck by hand onto taper of arbor.
4. Use chuck key to completely retract jaws (to prevent damage to jaws). Use two or three sharp taps from a rubber mallet, or a hammer and a block of wood, against bottom of chuck to seat chuck securely onto arbor.

**CAUTION** Do not use a steel hammer directly against chuck, as this may damage chuck.

## 7.0 Electrical Connections

**WARNING** Electrical connections must be made by a qualified electrician in compliance with all relevant codes. This machine must be properly grounded to help prevent electrical shock and possible fatal injury.

The PM2815BT drill press is rated and prewired for 120V power. The drill press comes with a plug designed for use on a circuit with a grounded outlet that looks like the one pictured in **A**, Figure 7-1.

Before connecting to power source, be sure switch is in *off* position.

It is recommended that the drill press be connected to a dedicated, minimum 20-amp circuit with circuit breaker or time-delay fuse marked “D”. **Local codes take precedence over recommendations.**

### 7.1 Grounding Instructions

#### 1. All Grounded, Cord-connected Tools:

In the event of a malfunction or breakdown, grounding provides a path of least resistance for electric current to reduce the risk of electric shock. This tool is equipped with an electric cord having an equipment-grounding conductor and a grounding plug. The plug must be plugged into a matching outlet that is properly installed and grounded in accordance with all local codes and ordinances.

Do not modify the plug provided - if it will not fit the outlet, have the proper outlet installed by a qualified electrician.

Improper connection of the equipment-grounding conductor can result in a risk of electric shock. The conductor with insulation having an outer surface that is green with or without yellow stripes is the equipment-grounding conductor. If repair or replacement of the electric cord or plug is necessary, do not connect the equipment-grounding conductor to a live terminal.

**WARNING** Check with a qualified electrician or service personnel if the grounding instructions are not completely understood, or if in doubt as to whether the tool is properly grounded. Failure to comply may cause serious or fatal injury.

Use only 3-wire extension cords that have 3-prong grounding plugs and 3-pole receptacles that accept the tool's plug. Repair or replace damaged or worn cord immediately.

2. Grounded, cord-connected tools intended for use on a supply circuit having a nominal rating **less than 150 volts:**

This tool is intended for use on a circuit that has an outlet that looks like the one illustrated in **A**, Figure 7-1. An adapter, shown in **B** and **C**, may be used to connect this plug to a 2-pole receptacle as shown in **B** if a properly grounded outlet is not available. The temporary adapter should be used only until a properly grounded outlet can be installed by a qualified electrician. *This adapter is not permitted in Canada.* The green-colored rigid ear, lug, and the like, extending from the adapter must be connected to a permanent ground such as a properly grounded outlet box.

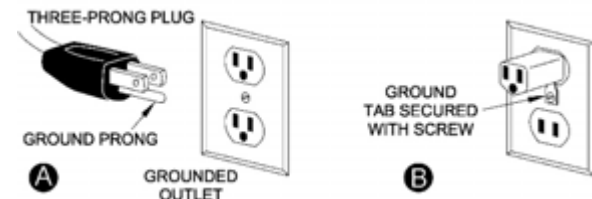

Figure 7-1

### 7.2 Extension Cords

The use of extension cords is discouraged; try to position machines near the power source. If an extension cord is necessary, make sure it is in good condition. When using an extension cord, be sure to use one heavy enough to carry the current your product will draw. An undersized cord will cause a drop in line voltage resulting in loss of power and overheating. Table 2 shows correct size to use depending on cord length and nameplate ampere rating. If in doubt, use the next heavier gauge. The smaller the gauge number, the heavier the cord.

Amp Rating		Volts	Total length of cord in feet			
More Than	Not More Than	120	25	50	100	150
			AWG			
0	6		18	16	16	14
6	10		18	16	14	12
10	12		16	16	14	12
12	16		14	12	Not Recommended	

Table 2: Extension Cord Recommendations

## 8.0 Adjustments

Note: All Figures may not match your drill press model or may show optional accessories mounted.

### 8.1 Table Movement

#### 8.1.1 Raise and Lower

Loosen table locking handle (A, Figure 8-1). Turn crank handle (B) to raise or lower table along

column rack. Re-tighten locking handle (A) before attempting to drill.

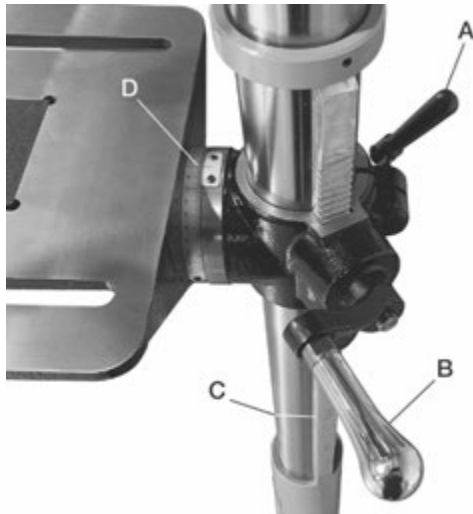

Figure 8-1

### 8.1.2 Swing Table Away

Refer to Figure 8-1.

When drilling into a long workpiece, swing table out of the way and use drill press base as your table. Slots in the base can be used to mount work holding devices.

1. Loosen table locking handle (A).
2. Swing table to desired position. If rack (C) tends to bind, you will need to nudge the top or bottom end of the rack around the column while swinging table. Keeping a light coat of oil on the column will help prevent any binding.
3. Tighten table locking handle (A).

### 8.1.3 Tilt Table

Refer to Figure 8-2.

1. Loosen hex screw (E) to pivot table to desired angle. Refer to scale and indicator plate (D, Figure 8-1). Tighten hex screw (E) after setting desired angle.

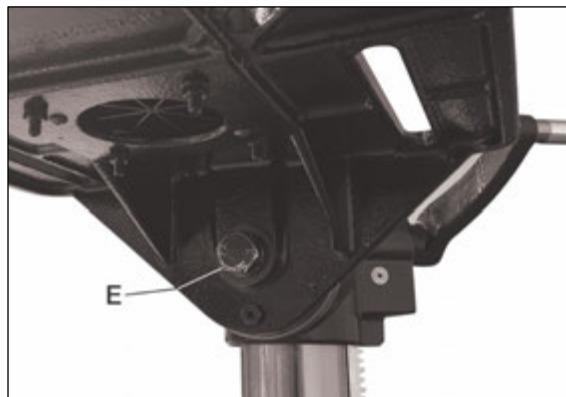

Figure 8-2

## 8.2 Chuck and Arbor Removal

Refer to Figure 8-3

1. Disconnect machine from power source.
2. Lower quill assembly with turret handles to expose slot. Rotate chuck to align slots.
3. Insert drift key into slot.
4. Tap drift key into slot until chuck and arbor fall out. **NOTE:** Hold on to chuck to prevent it being damaged as it falls.



Figure 8-3

## 8.3 Depth Stop

The depth stop is used for repetitive drilling of holes of identical depth.

Depth stop can be established by one of two procedures (see Figures 8-4 thru 8-6):

### Method #1:

1. Raise the table until the drill bit just contacts the top surface of workpiece, as shown in Figure 8-4.

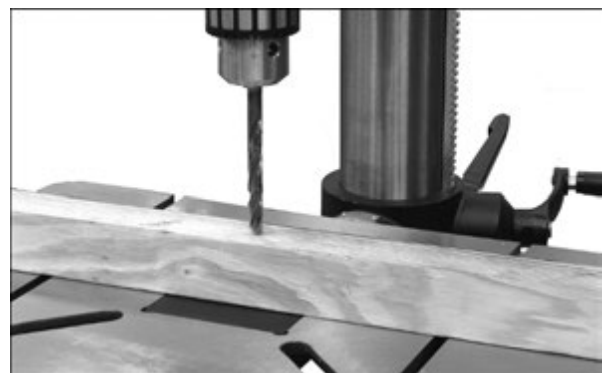

Figure 8-4: method #1

2. Loosen lock knob (F) and rotate the scale ring (H) to the desired depth.
3. Tighten the lock knob (F).
4. The bit can now be repeatedly lowered to the pre-set depth using the turret handles.
5. To release the depth-stop, loosen lock handle (F).



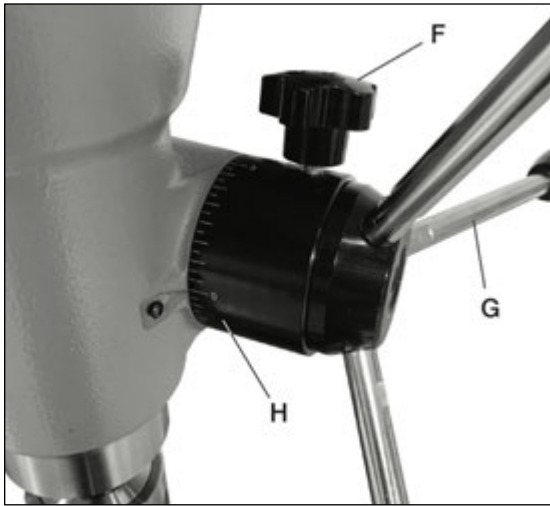

Figure 8-5

**Method #2:**

1. Mark the desired depth of cut on the side of the workpiece (Figure 8-6).
2. Loosen lock handle (F) and use turret handles (G) to lower the bit to the mark. Hold turret handle in position.
3. Rotate the scale ring (H) to the measurement that will allow the drill bit to raise and clear the workpiece.
4. Tighten the lock handle (F).
5. The bit will now stop at the marked depth when the turret handles are rotated.
6. To release depth stop, loosen lock handle (F).

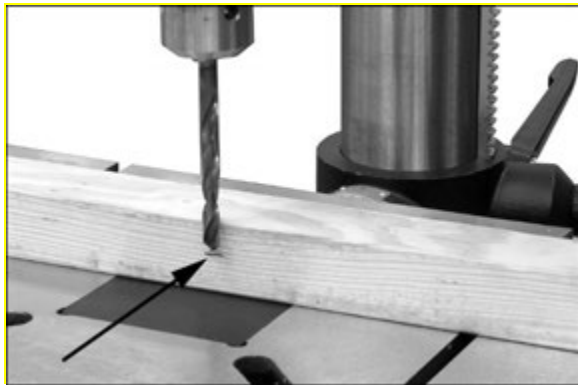

Figure 8-6: method #2

**8.4 Quill Retraction Lock**

The quill can be held in the down position and prevented from retracting, such as for operating a sanding drum or to facilitate removal of chuck and arbor.

To lock the quill in down position, proceed as follows (Figure 8-5):

1. Loosen lock handle (F).

2. Rotate turret handles (G) to lower spindle to the point at which it is to be locked, and hold turret handles stationary in this position.
3. Rotate scale ring (H) *clockwise* all the way until it stops. You should be able to feel and hear when lock ring reaches the end of its rotation.
4. Tighten lock handle (F). You can now release turret handles. The quill will remain in this lowered position until released.
5. To release the quill, loosen lock handle (F).

**8.5 Laser Adjustment**

**WARNING** Do not look directly into the laser beam or view it directly with optical instruments. See Figure 8-7.



Figure 8-7

The Laser Assembly has been installed and pre-set at the factory. It should, however, be checked for alignment and any adjustments made before operating the drill press. It should be re-checked periodically, as long-term machine vibration may cause it to become misaligned.

**Cross Hair Alignment**

1. Place a wooden board (J, Figure 8-8) flat on table. Do not allow board to move from this position; use clamps if needed. Bring the bit down until it leaves a slight indentation in the board; then raise the bit back up.
2. Loosen the laser setscrew on one side of the drill press head (see Figure 8-9). Using your thumb and forefinger, slightly rotate the laser left or right until it bisects the drill bit indentation on the board (K, Figure 8-8). Tighten the laser set screw to lock this laser in place.
3. Repeat step 2 with the laser on the other side of the drill press head. Make sure the second laser bisects the drill bit indentation (L, Figure 8-8). The two lasers will now form an "X" with the center of the "X" at the precise point of the drill bit indentation.

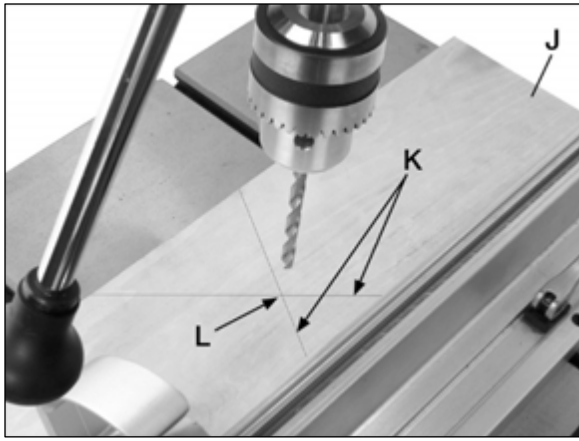

Figure 8-8

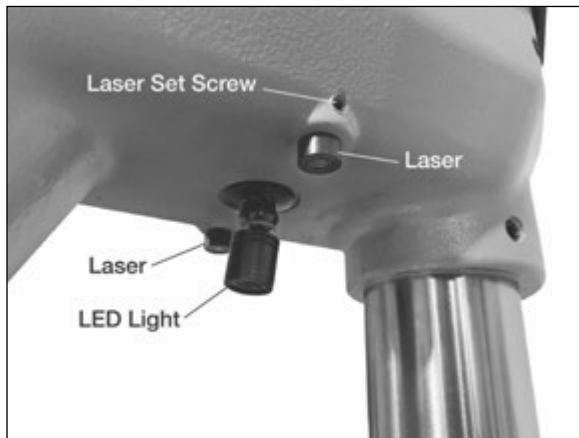

Figure 8-9

The laser is now properly aligned, and the location of your holes can be centered at the cross hairs for accurate drilling.

## 8.6 LED Light

The LED light is activated by the front panel switch. Press on the outer rim of the light to adjust (see Figure 8-9).

## 9.0 Operating Controls

Refer to Figure 9-1.

**Main switch – (A).** Pull out to engage power; push in to stop all functions of the drill press. Spindle coasting will stop within 5 seconds.

**Safety key – (B).** The main switch has a safety feature that prevents unauthorized or accidental starting of the drill press. Push in main switch and slide out safety key. This piece must be re-inserted before the drill press can operate.

**Power indicator lamp (green) – (C).** The lamp is on whenever there is power connected to the Drill Press, not just when the Drill Press is running.

**⚠WARNING** Do not assume that no light means there is no power to the machine. If the bulb is bad, there will be no indication. Always check before use.

**Spindle rotation ON – (D)**

**Spindle rotation OFF – (E).** Spindle coasting will stop within 10 seconds from maximum RPM.

**Laser switch – (F)**

**LED switch – (G)**

**Spindle speed dial – (H).** Adjust during spindle rotation. Speed in RPM will show on the display.

If a power outage occurs, when power resumes, push OFF button (E) then ON button (D) to restart the drill press.



Figure 9-1

## 10.0 Operation

### 10.1 Installing Bits

Insert bit (not provided) into chuck jaws with about 1" insertion. When using a small bit, do not insert it so far that the jaws touch the flutes of the bit. Make sure bit is centered in chuck before tightening chuck. Insert chuck key into hole in the side of chuck and turn the key clockwise to tighten bit in chuck.

### 10.2 Positioning Work Piece

**⚠WARNING** Whenever possible, use clamps or work hold-downs to secure the work piece to the table.

Always secure the work piece to prevent it being torn from the operator's hand. Using the column as a work stop is not recommended; instead, use holding devices such as clamps. When using the

table in tilted position, make sure the table is securely tightened and the work piece is clamped sufficiently.

For clean, splinter-free holes, place a piece of scrap wood on the table below the work piece.

Perform operations with a minimum extension of the quill. Adjust table position rather than using excessive quill travel.

Feed bit into the material with only enough force to allow the bit to work. Feeding too slowly may cause burning of the work piece. Feeding too quickly may cause the motor to slow and/or the bit to break.

### 10.3 General Inspection

Before each operation of your PM2815BT drill press, make a habit of checking that all locking handles, set screws, bolts, etc., are tight on the table and head. Confirm that drill bit is securely inserted inside chuck jaws.

Clear all items, such as tools and rags, away from machine.

Before attempting regular work, get the feel of the drill press by practicing on scrap material. For best results, always use sharp bits and proper feed rates.

### 10.4 Speed Setting

There are several factors which determine the best speed to use in any drill press operation, such as kind of material being worked, size of hole, type of drill, and quality of cut desired.

A general rule of thumb is, the smaller the drill, the greater the required RPMs. And the speed should be faster for soft materials and slower for harder materials.

## 11.0 User-Maintenance

**⚠WARNING** Before doing maintenance on the machine, disconnect it from electrical supply. Unplug machine from the electrical source and press in the main switch to the OFF position and insert the safety key. Failure to comply may cause serious injury.

Bearings on the drill press are self-contained and permanently lubricated; no further lubrication is needed.

*After each use:*

Clean sawdust from the table with a brush (do not use bare hands).

*Periodically:*

Apply a light film of oil to the quill and column. This will reduce wear, prevent rust, and assure ease of operation.

Apply grease to the rack on the column.

Check that bolts are tight and the electrical cord is in good condition.

Exposed metal surfaces of table and base should be kept clean and free of rust. Protective sprays or paste wax are available from most hardware stores. Note: Avoid wax that contains silicone or other synthetic ingredients; these materials can find their way into lumber and make staining and finishing difficult.

*Annually:*

The quill return spring should receive SAE 20 oil once yearly. Remove the outside cover and apply the oil beneath the coil spring cover (see Figure 11-1) using a squirt can.



Figure 11-1



## 12.0 Troubleshooting the PM2815BT Drill Press

### 12.1 Mechanical and Electrical

\* **WARNING:** Some corrections may require a qualified electrician.

Symptom	Possible Cause	Correction *
Drill press will not start (power light is OFF).	Not connected to power.	Check all plug connections.
	Fuse blown, or circuit breaker tripped on main panel.	Replace fuse or reset circuit breaker.
	Power cord damaged.	Replace cord.
Drill press will not start (power light is ON).	Safety key removed.	Install safety key.
	Switch malfunction.	Have switch tested and replaced if needed.
Drill press does not come up to speed.	Extension cord too light or too long.	Replace with adequate size and length cord.
	Low current.	Contact a qualified electrician.
	Motor malfunction.	Have motor tested by a qualified service center. Repair or replace as necessary.
Motor stalls.	Overfeeding the bit.	Reduce feed rate.
	Dull bit.	Sharpen or replace bit.
	Motor not reaching running speed.	Repair or replace motor.
	Motor malfunction.	Have motor tested by a qualified service center. Repair or replace as necessary.
Noisy Operation.	Excessive vibration.	Tighten any loose parts. Drill press should sit evenly on level floor. Secure drill press to floor or plywood base.
	Dry spindle.	Lubricate spindle.
Wood splinters on underside of work piece.	No backing board used.	Place scrap board beneath work piece to prevent splintering.
Drill or tool heats up or burns work piece.	Excessive speed.	Reduce speed.
	Chips not clearing from hole or bit.	Retract drill bit frequently to remove chips.
	Dull drill bit.	Resharpen, or replace drill bit.
	Feeding bit too slowly.	Increase feed rate.
Drill bit wanders.	Bit sharpened incorrectly.	Resharpen bit correctly.
	Bent drill bit.	Replace bit.
	Bit or chuck not installed properly.	Reinstall chuck or bit.
Drill bit binds in work piece.	Work piece pinching the bit.	Support or clamp work piece.
	Excessive feed rate.	Decrease feed rate.
	Chuck jaws not tight.	Tighten chuck jaws.
Spindle does not retract properly.	Return spring out of adjustment.	Contact Powermatic technical support.

## 12.2 Error Codes on Digital Readout

Error code	Error source	Description	Correction
ERR-1	Overload protector	If load exceeds 15A for over 5 seconds, PCB shuts off motor.	Press off button to clear error code, then press on to restart machine.
ERR-2	Motor revolution sensor	Motor won't start within 25 seconds of turning on switch; motor burned out.	Replace motor.
ERR-3	Motor revolution sensor	Spindle is blocked from turning longer than 1 sec.	Investigate reason for spindle blockage. Press off button to clear error code, and restart machine.
ERR-4	PCB broken, IGBT	Motor will not restart until PCB is replaced.	Replace PCB.
ERR-5	Clutch movement during spindle running.	Clutch action (Hi-Lo gear setting) not allowed while spindle is running.	Check that Hi-Lo lever is properly engaged in detent. Do not attempt to change lever while spindle is running. Press off button to clear error code, then press on to restart.
		Clutch not fully engaged (Hi-Lo lever not properly engaged in detent).	
ERR-6	Over voltage	AC input power is more than 140V, shuts off motor.	Press off button to clear error code, then press on to restart.
ERR-7	Low voltage	AC input power is less than 80V, shuts off motor.	Press off button to clear error code, then press on to restart.
ERR-8	Heat sink overheated	IGBT heated over 221°F (105°C); shuts off motor.	Allow cool down. Press off button to clear error code, then press on to restart.

## 13.0 Replacement Parts

Replacement parts are listed on the following pages. To order parts or reach our service department, call 1-800-274-6848 Monday through Friday, 8:00 a.m. to 5:00 p.m. CST. Having the Model Number and Serial Number of your machine available when you call will allow us to serve you quickly and accurately.

Non-proprietary parts, such as fasteners, can be found at local hardware stores, or may be ordered from Powermatic. Some parts are shown for reference only and may not be available individually.

13.1.1 PM2815BT Gear Box Assembly – Exploded View

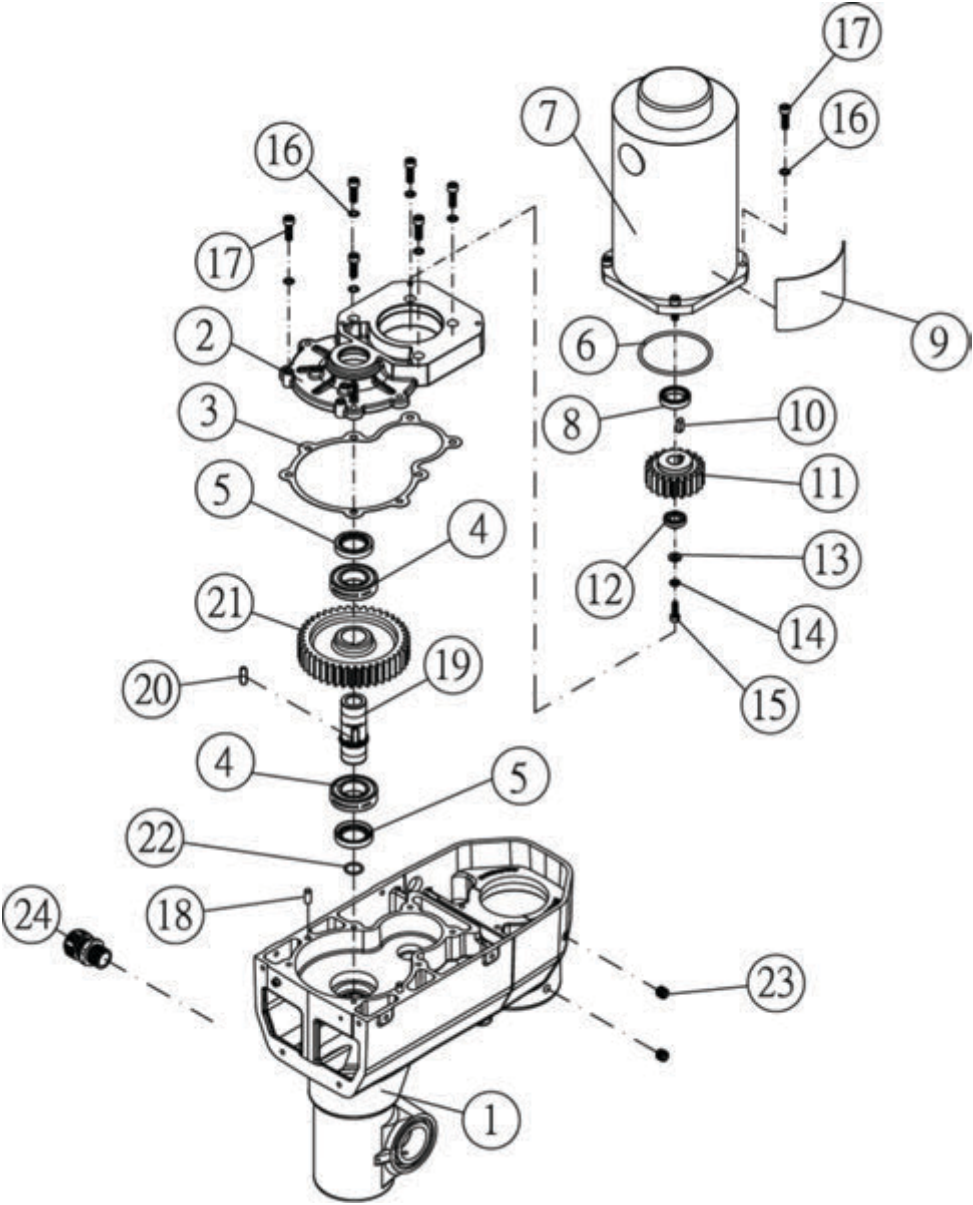

### 13.1.2 PM2815BT Gear Box Assembly – Parts List

Index No.	Part No.	Description	Size	Qty.
1	PM2815BT-101	Headstock		1
2	PM2815BT-102	Gear Box Cover		1
3	PM2815BT-103	Gasket		1
4	BB-6005ZZ	Ball Bearing	6005ZZ	2
5	PM2820EVS-126	Oil Seal	25x38x07V	2
6	PM2815BT-106	O - Ring	64.4mm x 3.1mm	1
	PM2815BT-MA	Motor Assembly (Item #6 - #15)		1
7	PM2815BT-107	DC Motor (Item #7- #9)		1
	PM2815BT-MCB	Motor Carbon Brush (not shown)		1
	PM2820EVS-MCBC	Motor Carbon Brush Cap (not shown)		1
8	PM2815BT-108	Oil Seal	20x30x7	1
9	PM2815BT-109	Motor Label		1
10	PM2815BT-110	Key	5x5x15mm	1
11	PM2815BT-111	Motor Gear		1
12	PM2820EVS-175	Flange		1
13	TS-1550041	Flat Washer	M6	1
14	TS-1550031	Flat Washer	M5	1
15	TS-1502041	Socket Head Cap Screw	M5-0.8Px16	1
16	TS-2361061	Lock Washer	M6	10
17	TS-1503051	Socket Head Cap Screw	6-1.0Px20	10
18	PM2820EVS-153	Pin	φ 6x16	2
19	PM2815BT-119	Shaft		1
20	PM2815BT-120	Key	6x6x20	1
21	PM2815BT-121	Spindle Gear		1
22	PM2815BT-122	O-Ring	15mm x 2mm	1
23	TS-1525011	Set Screw	M10-1.5Px10	2
24	PM2820EVS-150	Strain Relief	M20	1

### 13.2.1 PM2815BT Quill and Laser Assembly – Exploded View

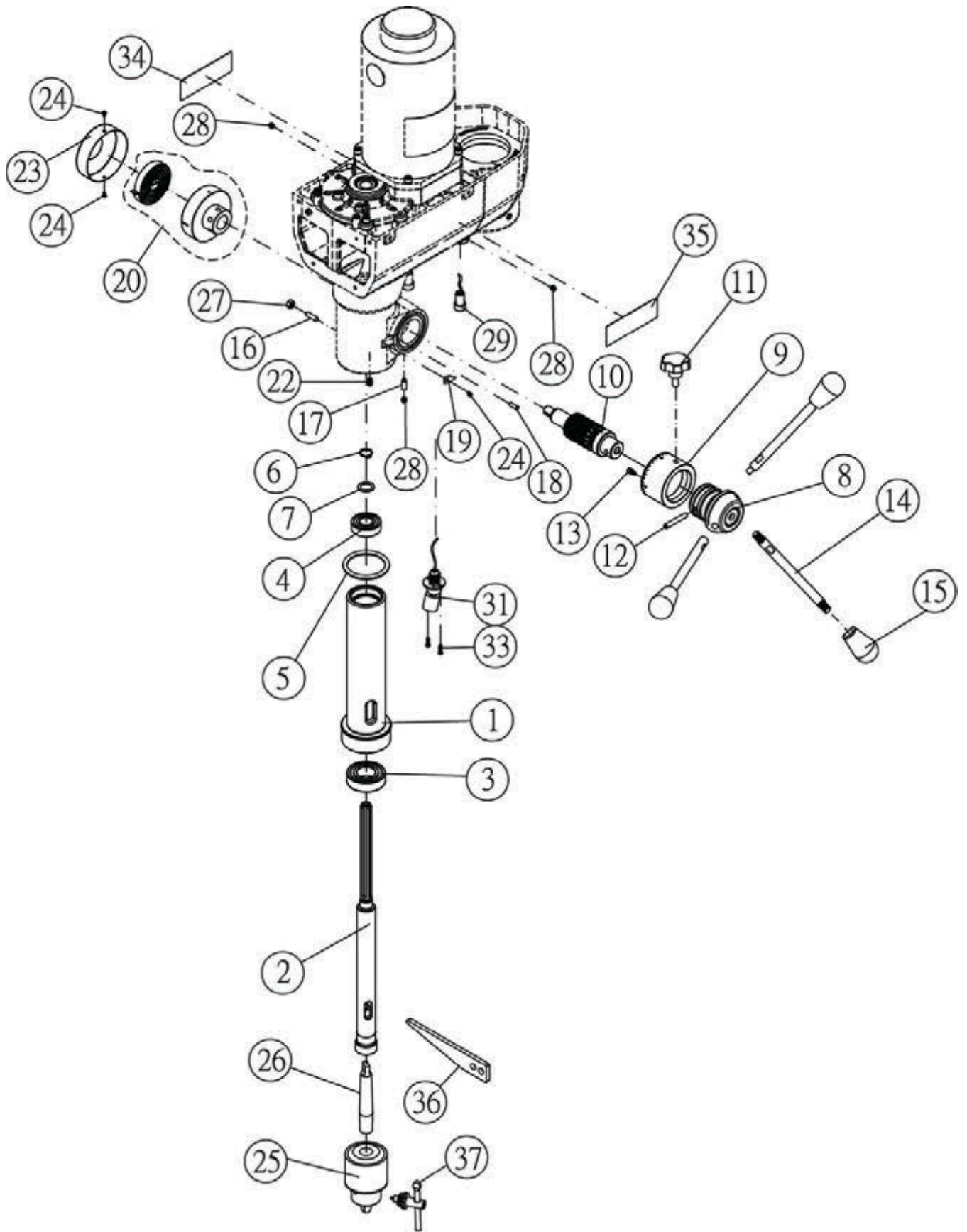

### 13.2.2 PM2815BT Quill and Laser Assembly – Parts List

Index No.	Part No.	Description	Size	Qty.
	PM2815BT-SA	Spindle Assembly (Item #1-#7)		1
1	PM2815BT-201	Quill		1
2	PM2815BT-202	Spindle		1
3	BB-6205VV	Ball Bearing	6205LLB	1
4	BB-6203VV	Ball Bearing	6203LLB	1
5	PM2820EVS-251	O-Ring	51.6x 5.7mm	1
6	JWP13BT-227	S-Ring	STW-15	1
7	PM2815BT-207	Washer	15x22x1.0mm	1
8	PM2815BT-208	Hub		1
9	PM2815BT-209	Depth Limited Scale	Inch	1
10	PM2815BT-210	Feed Shaft		1
11	PM2815BT-211	Lock Knob		1
12	PM2815BT-212	Spring Pin	φ 6x40mm	1
13	TS-1501021	Socket Head Cap Screw	M4x8	1
14	PM2815BT-214	Feeding Handle	160mm	3
15	PM2820EVS-250	Knob	M10	3
16	PM2820EVS-236	Guide Screw	M6x20mm	1
17	PM2815BT-217	Screw	M6x16mm	1
18	PM2815BT-218	Pin	φ 5x15mm	1
19	PM2815BT-219	Pointer		1
20	PM2815BT-220	Coil Spring Kit		1
22	TS-1523031	Set Screw	M6-1.0x10	1
23	PM2815BT-223	Coil Spring Cover		1
24	TS-1524061	Socket Head Button Screw	M3x5	3
25	PM2820EVS-247	Keyed Chuck	5/8 JT3	1
26	PM2800-140	Arbor	MT2, JT3	1
27	TS-1540041	Hex Nut	M6-1.0	1
28	TS-1523011	Set Screw	M6-1.0 x 6	3
29	PM2815BT-229	Laser Kit		2
31	PM2815BT-231	LED Kit	DC12V/1.5W/6400K	1
33	PM2815BT-233	Socket Head Button Screw	M3x12mm	2
34	PM2820EVS-256	Laser Warning Label, French version		1
35	PM2820EVS-255	Laser Warning Label, English version		1
36	PM2800-136	Drift Key		1
37	PM2820EVS-249	Chuck Key		1

### 13.3.1 PM2815BT Control Panel – Exploded View

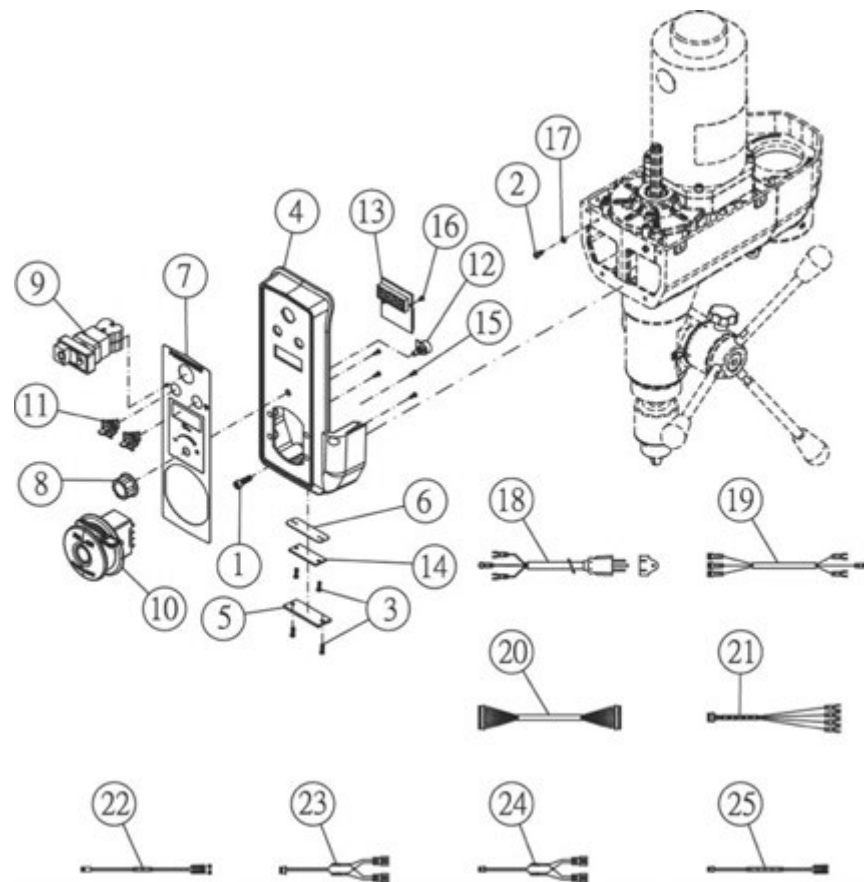

### 13.3.2 PM2815BT Control Panel – Parts List

Index No.	Part No.	Description	Size	Qty.
.....	PM2815BT-CPA.....	Control Panel Assembly (item #3 - #16).....		1
1.....	TS-1503051.....	Socket Head Cap Screw.....	6-1.0 x 20.....	4
2.....	TS-1501021.....	Socket Head Cap Screw.....	M4x8.....	2
3.....	PM2815BT-233.....	Socket Head Button Screw.....	M3x12mm.....	4
4.....	PM2815BT-304.....	Front Panel Frame (Item #4 & #7).....		1
5.....	PM2815BT-305.....	LED Light Cover.....		1
6.....	PM2815BT-306.....	Plate.....		1
7.....	PM2815BT-307.....	Label.....		1
8.....	PM2820EVS-303.....	Knob with Screw.....		1
9.....	PM2820EVS-306.....	Control Switch.....		1
.....	PM2800-103-1.....	Switch Safety Key.....		1
10.....	PM2820EVS-308.....	Main Switch (* includes Switch Safety Key).....		1
11.....	PM2820EVS-305.....	Momentary Switch.....		2
12.....	PM2820EVS-302.....	Control Pot Assembly.....		1
13.....	PM2820EVS-304.....	Digital Readout.....		1
14.....	PM2815BT-314.....	LED Light Board.....		1
15.....	TS-2283102.....	Machine Screw.....	M3x10.....	4
16.....	TS-2283061.....	Machine Screw.....	M3x6.....	2
17.....	TS-0733031.....	External Tooth Washer.....	#10.....	2
18.....	PM2820EVS-314.....	Power Cable.....		1
19.....	PM2820EVS-316.....	Power Cable, Terminal to PCB.....		1
20.....	PM2820EVS-319.....	Signal wire, PCB to digital readout.....		1
21.....	PM2820EVS-320.....	Connection Wire, digital readout to control switch.....		1
22.....	PM2820EVS-322.....	Laser Wire, PCB to Laser.....		1
23.....	PM2815BT-323.....	LED Light Wire, momentary switch to Power.....		1
24.....	PM2815BT-324.....	Laser Wire, momentary switch to PCB.....		1
25.....	PM2815BT-325.....	LED Light wire, momentary switch & Power to LED light.....		1
26.....	PM2815BT-326.....	Thermal Protector wire, PCB to digital readout (not shown).....		1



### 13.4.1 PM2815BT Top Cover & PCB Assembly – Exploded View

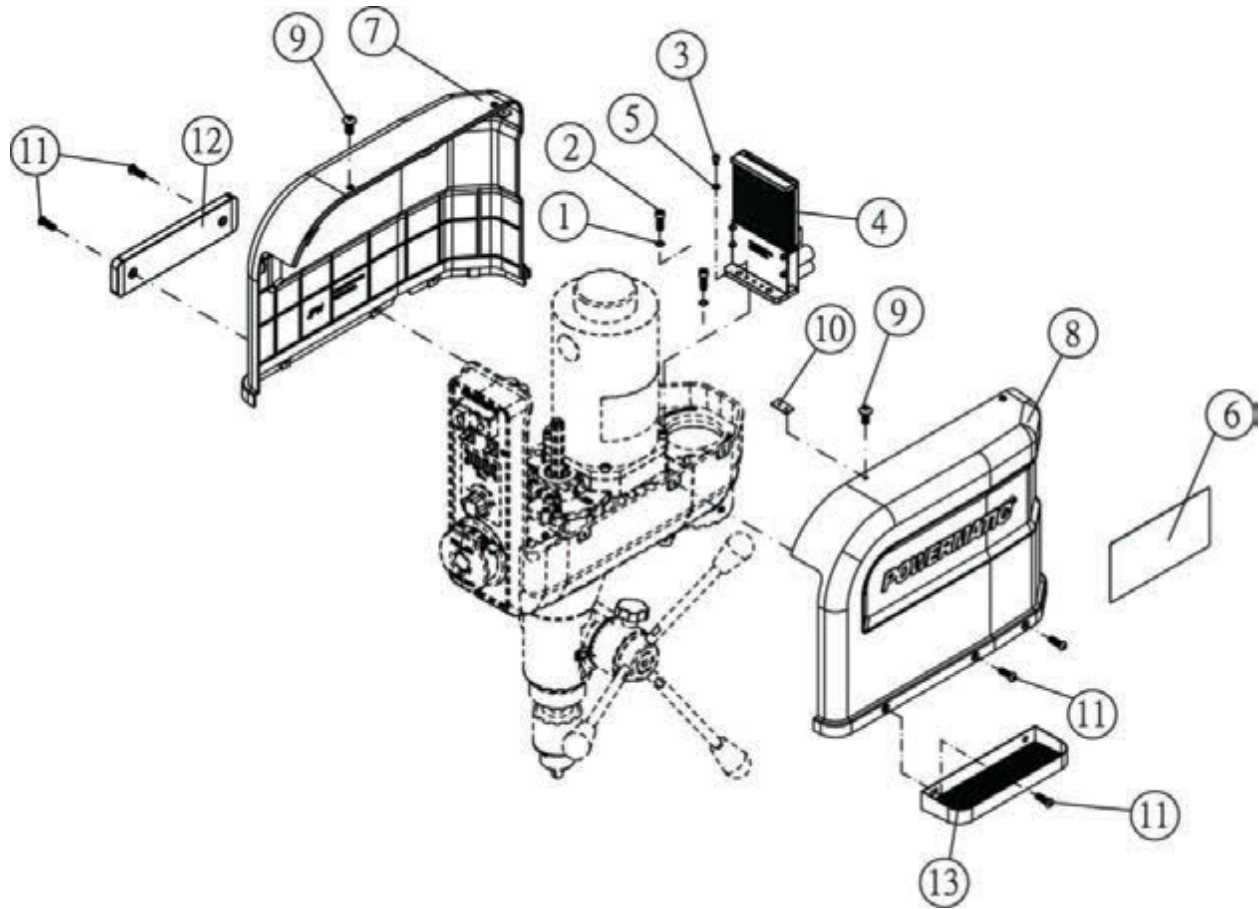

### 13.4.2 PM2815BT Top Cover & PCB Assembly – Parts List

Index No.	Part No.	Description	Size	Qty.
1.....	TS-2361061.....	Lock Washer .....	M6.....	2
2.....	TS-1503051.....	Socket Head Cap Screw .....	6x20.....	2
3.....	TS-1501021.....	Socket Head Cap Screw .....	M4x8.....	1
4.....	PM2815BT-404.....	PCB Assembly .....		1
5.....	TS-0733031.....	External Tooth Washer .....	#10.....	1
6.....	PM2815BT-406.....	Warning Label .....		1
7.....	PM2815BT-407.....	Top Cover, Left.....		1
8.....	PM2815BT-408.....	Top Cover, Right (Included #6).....		1
9.....	TS-2244102.....	Socket Head Button Screw .....	M4x10.....	4
10.....	PM2820EVS-405.....	Steel Plate.....		2
11.....	TS-2246202.....	Socket Head Button Screw .....	M6x20.....	6
12.....	1792822.....	Tool Holder (OPTIONAL ACCESSORY) .....		1
13.....	1792821.....	Storage Set (OPTIONAL ACCESSORY) .....		1
14.....	PM2820EVS-416.....	Fuse, PCB (not shown).....	20A.....	1

13.5.1 PM2815BT Work Table Assembly – Exploded View

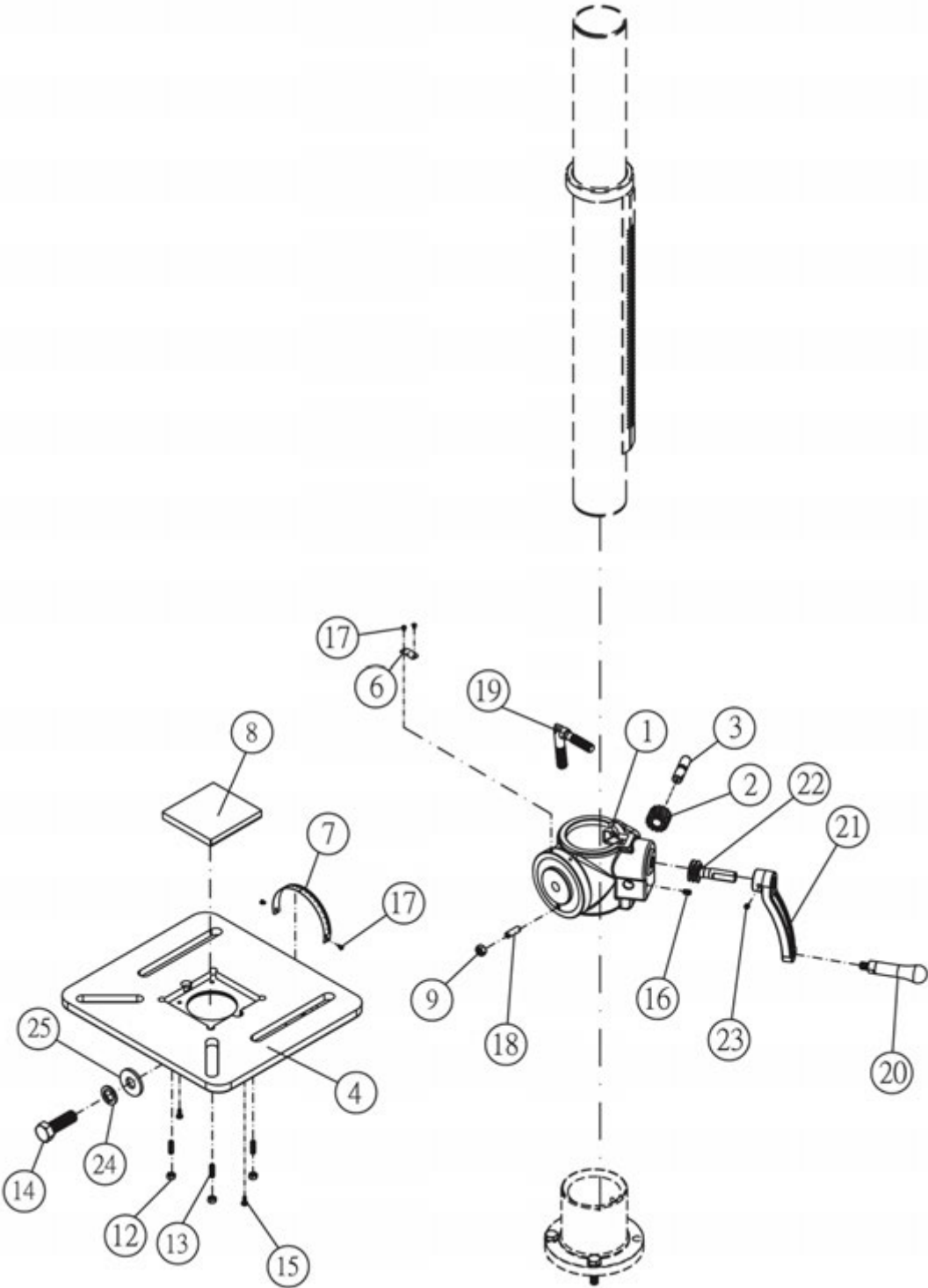

### 13.5.2 PM2815BT Work Table Assembly – Parts List

Index No.	Part No.	Description	Size	Qty.
	PM2815BT-TA	Table Assembly (item #1 - #25)		1
1	PM2815BT-501	Table Bracket		1
2	PM2820EVS-502	Gear		1
3	PM2820EVS-503	Shaft		1
4	PM2815BT-504	Main Table		1
6	PM2820EVS-506	Pointer		1
7	PM2820EVS-507	Angle Scale		1
8	PM2820EVS-508	Table Insert		1
9	TS-1540061	Hex Nut	M8-1.25P	1
12	TS-1540041	Hex Nut	M6	4
13	PM2820EVS-513	Set Screw	M6x20	4
14	TS-2213501	Hex Cap Screw	M16x50	1
15	TS-1532052	Machine Screw	M4x16	2
16	TS-1523031	Set Screw	M6x10	1
17	PM2820EVS-517	Socket Head Button Screw	M3x5	4
18	PM2815BT-518	Screw		1
19	PM2815BT-519	Lock Handle		1
20	PM2820EVS-520	Handle		1
21	PM2820EVS-521	Crank Arm		1
22	PM2820EVS-522	Worm Shaft		1
23	TS-1523011	Set Screw	M6x6	1
24	TS-2361161	Lock Washer	M16	1
25	TS-155010	Flat Washer	M16	1

### 13.6.1 PM2815BT Column Assembly – Exploded View

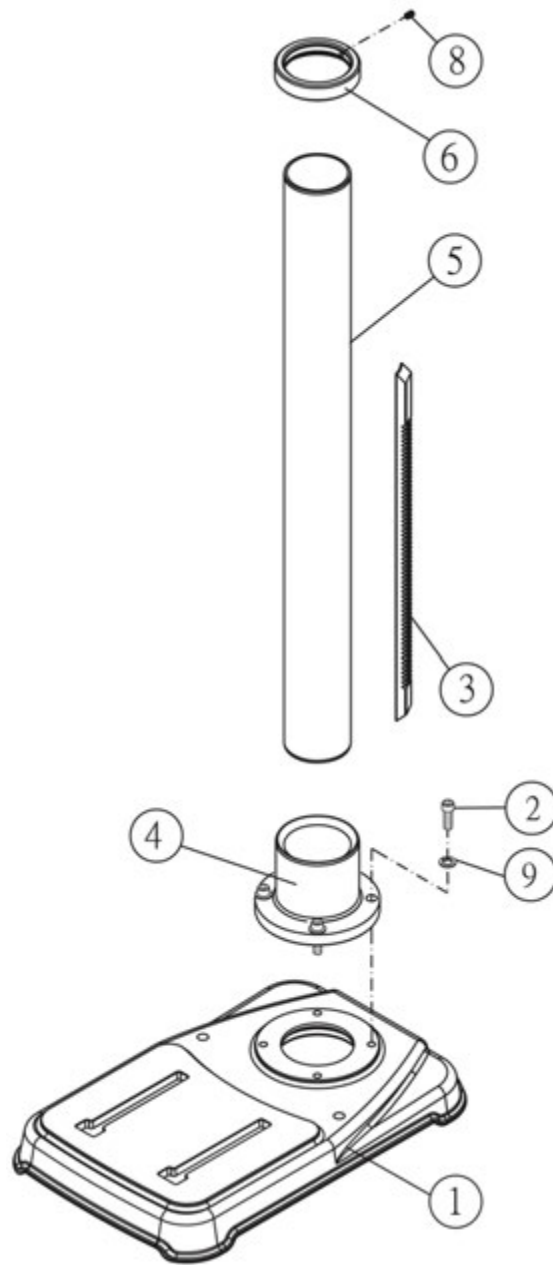

### 13.6.2 PM2815BT Column Assembly – Parts List

Index No.	Part No.	Description	Size	Qty.
1	PM2815BT-701	Base		1
2	TS-1505051	Socket Head Cap Screw	M10x35	4
3	PM2815BT-703	Rack	Benchtop	1
4	PM2815BT-704	Column Holder Kit (Item #4 & #5)	Benchtop	1
5		Column	Benchtop	1
6	PM2815BT-706	Rack Ring		1
8	TS-1523031	Set Screw	M6x10	1
9	TS-2361101	Lock Washer	M10	4
10	PM2815BT-710	I.D label, PM2815BT	Benchtop	1

## 14.0 Optional accessories

The following items will add functionality to your machine. See our website for more details, and to order accessories.

1792821 Storage Set

1792822 Tool Holder

# 15.0 Electrical Connections for PM2815BT Drill Press

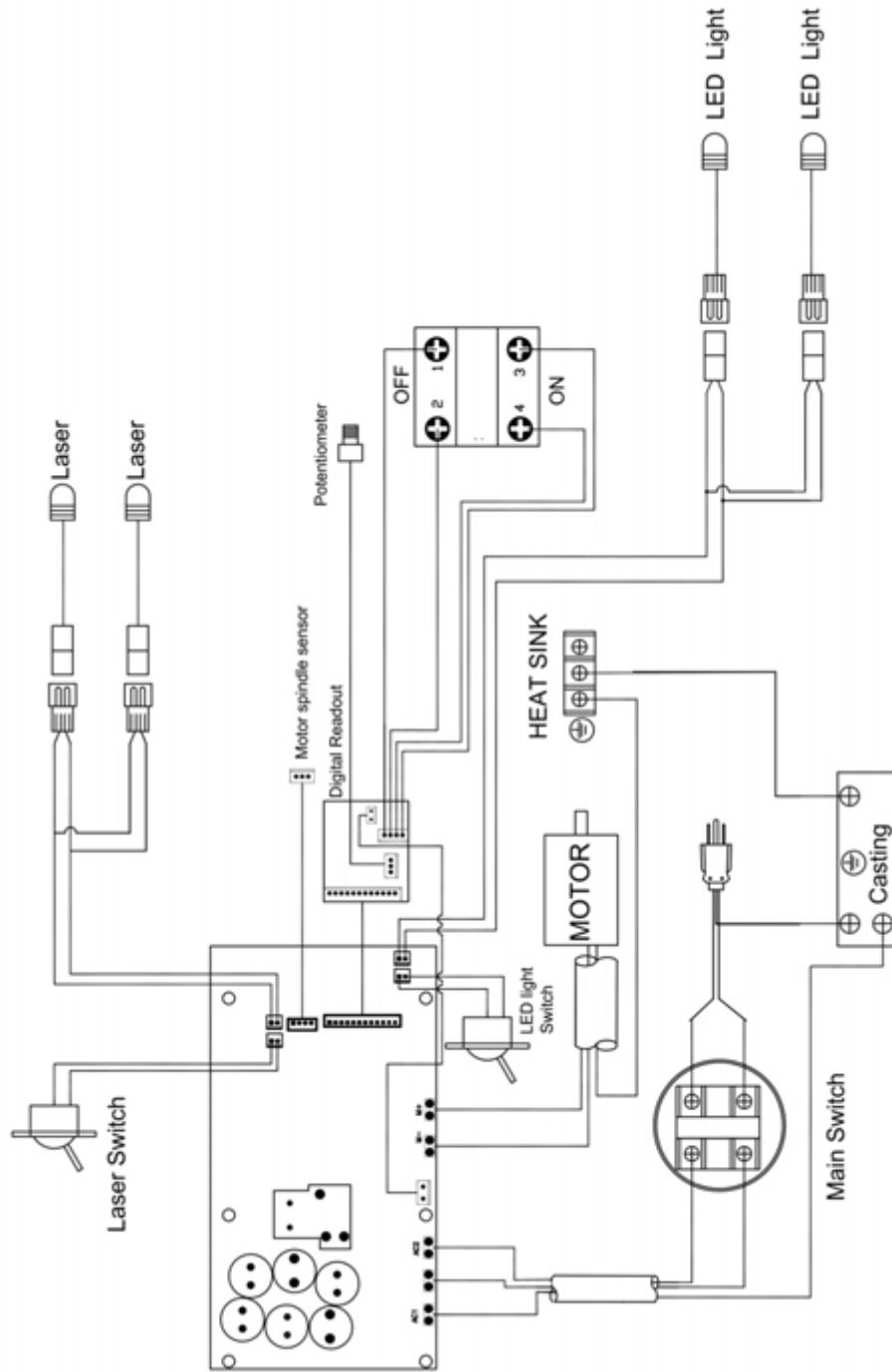

## 16.0 Warranty and Service

Powermatic warrants every product it sells against manufacturers' defects. If one of our tools needs service or repair, please contact Technical Service by calling 1-800-274-6846, 8AM to 5PM CST, Monday through Friday.

### Warranty Period

The general warranty lasts for the time period specified in the literature included with your product or on the official Powermatic branded website.

- Powermatic products carry a limited warranty which varies in duration based upon the product. (See chart below)
- Accessories carry a limited warranty of one year from the date of receipt.
- Consumable items are defined as expendable parts or accessories expected to become inoperable within a reasonable amount of use and are covered by a 90-day limited warranty against manufacturer's defects.

### Who is Covered

This warranty covers only the initial purchaser of the product from the date of delivery.

### What is Covered

This warranty covers any defects in workmanship or materials subject to the limitations stated below. This warranty does not cover failures due directly or indirectly to misuse, abuse, negligence or accidents, normal wear-and-tear, improper repair, alterations, or lack of maintenance. Powermatic woodworking machinery is designed to be used with Wood. Use of these machines in the processing of metal, plastics, or other materials may void the warranty. The exceptions are acrylics and other natural items that are made specifically for wood turning.

### Warranty Limitations

Woodworking products with a Five-Year Warranty that are used for commercial or industrial purposes default to a Two-Year Warranty. Please contact Technical Service at 1-800-274-6846 for further clarification.

### How to Get Technical Support

Please contact Technical Service by calling 1-800-274-6846. **Please note that you will be asked to provide proof of initial purchase when calling.** If a product requires further inspection, the Technical Service representative will explain and assist with any additional action needed. Powermatic has Authorized Service Centers located throughout the United States. For the name of an Authorized Service Center in your area call 1-800-274-6846 or use the Service Center Locator on the Powermatic website.

### More Information

Powermatic is constantly adding new products. For complete, up-to-date product information, check with your local distributor or visit the Powermatic website.

### How State Law Applies

This warranty gives you specific legal rights, subject to applicable state law.

### Limitations on This Warranty

POWERMATIC LIMITS ALL IMPLIED WARRANTIES TO THE PERIOD OF THE LIMITED WARRANTY FOR EACH PRODUCT. EXCEPT AS STATED HEREIN, ANY IMPLIED WARRANTIES OF MERCHANTABILITY AND FITNESS FOR A PARTICULAR PURPOSE ARE EXCLUDED. SOME STATES DO NOT ALLOW LIMITATIONS ON HOW LONG AN IMPLIED WARRANTY LASTS, SO THE ABOVE LIMITATION MAY NOT APPLY TO YOU.

POWERMATIC SHALL IN NO EVENT BE LIABLE FOR DEATH, INJURIES TO PERSONS OR PROPERTY, OR FOR INCIDENTAL, CONTINGENT, SPECIAL, OR CONSEQUENTIAL DAMAGES ARISING FROM THE USE OF OUR PRODUCTS. SOME STATES DO NOT ALLOW THE EXCLUSION OR LIMITATION OF INCIDENTAL OR CONSEQUENTIAL DAMAGES, SO THE ABOVE LIMITATION OR EXCLUSION MAY NOT APPLY TO YOU.

Powermatic sells through distributors only. The specifications listed in Powermatic printed materials and on the official Powermatic website are given as general information and are not binding. Powermatic reserves the right to effect at any time, without prior notice, those alterations to parts, fittings, and accessory equipment which they may deem necessary for any reason whatsoever.

### Product Listing with Warranty Period

90 Days – Parts; Consumable items
1 Year – Motors, Machine Accessories
2 Year – Woodworking Machinery used for industrial or commercial purposes
5 Year – Woodworking Machinery

NOTE: Powermatic is a division of JPW Industries, Inc. References in this document to Powermatic also apply to JPW Industries, Inc., or any of its successors in interest to the Powermatic brand.



427 New Sanford Road  
LaVergne, Tennessee 37086  
Phone: 800-274-6848  
[www.powermatic.com](http://www.powermatic.com)