

Magnescale

Digital Gauge

DS50NR5 / DS50PR5 / DS100NR5 / DS100PR5

Instruction Manual

Read all the instructions in the manual carefully before use and strictly follow them.
Keep the manual for future references.

Trademarks

Microsoft Windows is the registered trademark of Microsoft Corporation.

Intel® Core™i3 is the registered trademark of Intel Corporation.

Other system names, product and service names described in the instruction manual are trademarks or registered trademarks of their corresponding manufacturers.

■ Specifications

	DS50NR5	DS50PR5	DS100NR5	DS100PR5
Communication Interface	USB2.0FS			
Resolution	0.5 μm			
Measuring range	50 mm		100 mm	
Accuracy (at 20°C)	4 μm p-p		5 μm p-p	
Measuring force (at 20°C)	Upward	–	–	9.3 N or less
	Horizontal	0.9±0.4 N	1.8±0.65 N	
	Downward	1.3±0.5 N	2.7±0.55 N	
Reference point	One location (at 1 mm position of spindle movement)			
Maximum response speed	250 m/min			
Vibration resistance (10 to 2000 Hz)	150 m/s ²			
Impact resistance (11 ms)	1500 m/s ²			
Protective structure	IP50	IP64	IP50	IP64
Operating temperature	0°C to +50°C			
Storage temperature	–20°C to +60°C			
Power supply voltage	DC +5 V ±5%			
Power consumption	1.2 W or less			
Diameter of stem	φ20 ⁰ _{–0.013} mm			
Mass *1	Approx. 360 g		Approx. 630 g	
Feeler	Provided with a carbide ball tip DZ-122 (Mount screw M2.5)			
Cable length	Measuring unit⇔Interpolation box : 2 m Interpolation box⇔USB : 0.5 m			
Accessories	Instruction Manual			
System requirement	CPU : Intel Core i3 or higher recommended RAM: 1 GB or higher recommended OS : Windows7, Windows10 (32bit/64bit of each edition)			

*1 The mass indicated is the total mass excluding the cable and interpolation box.

Magnescale Co., Ltd.

45 Suzukawa, Isehara-shi, Kanagawa 259-1146, Japan

DS50NR5 / DS50PR5 / DS100NR5 / DS100PR5
2-A02-934-1B

2020.9
Printed in Japan
©2020 Magnescale Co., Ltd.

■ Connecting the measuring unit

This measuring unit uses an interface that is compliant with the USB (Universal Serial Bus) 2.0 FS (Full speed) standard, and can be connected directly to a personal computer or hub.

Note

Use a personal computer that is compatible with the recommended system requirement (refer to “Specifications”).

■ Installing software

The software available on the Magnescale website can be used by installing in a personal computer. Refer to the software instruction manuals available on the Magnescale website for the software installation and operation methods.

Magnescale website

[https://www.magnescale.com/mgs/language/english/product/Digital Gauge > DS805S/DS812S](https://www.magnescale.com/mgs/language/english/product/Digital%20Gauge%20DS805S/DS812S)

■ Operating Cautions

- Do not use the unit in places where it may receive excessive shocks. Otherwise the inside of the unit may be damaged or the unit may become unable to produce normal output signals.
- Be sure to turn off the power before connecting or disconnecting connectors in order to prevent damage or misoperation.
- After mounting the measuring unit, insert the connector into the display unit until it locks. Be sure to turn off the power switch before connecting or disconnecting the connector.
- Locate the measuring unit (head built-in portion) at least 10 cm away from a strong magnetic source. (Do not exceed 5 mT in parallel magnetic fields.)
- Do not forcibly pull the cable for connecting or disconnecting, or it may cause breakage.
- The measuring unit is short circuited to the frame GND (ground terminal) of the display unit by shield wire of the cable. When the measuring unit is used with another signal processing device on a machine tool, etc., be aware of the ground level.
- The N-type measuring unit has an unsealed spindle for use in mechanical devices and measuring rooms having a favorable work environment. Due to the low measurement force, the N-type cannot be used with the spindle directed upward.
- The P-type measuring unit is dust-proof, drip-proof, and oil-resistant making it suitable for use in environments subject to chips, cutting oil, and machine oils. However, avoid immersing the P-type in cutting oil, etc., as it is not of a water-proof structure.
- Adhesion of cutting oil, etc. which increases in viscosity after drying, may hinder accurate spindle motion. Remove them with water or tepid water. Then apply machine oil or the like to the spindle.
- The P-type measuring unit is provided on the sliding portion of the spindle with an anti-drip/dust seal of nitrile rubber. Spindle movement may be impaired by exposure to cutting oil, water, etc. that may remove oil from the spindle surface.
- Recommended calibration interval 1 year.

■ Mounting Instructions

- Be sure to chuck the stem for mounting the measuring unit. If other portion of the measuring unit needs to be chucked, avoid chucking the name label portion (where the head is built in) and its neighborhood (Fig. 1).
- If the measuring unit is mounted on another device, ensure that the measuring unit is free from contact with mount screws.
- If excessive torque is applied on the spindle when screwing in the feeler, the internal mechanisms can be damaged. Therefore, screw in the feeler with your hands, and never use a tool. Except when using a flat feeler, it is recommended to either attach the spring washer (nominal size: 2.5) or use a screw lock to prevent loosening of the feeler. (Tightening torque reference value: 0.05–0.06 N·m)
- The measuring unit comprises ball bearings. Therefore, chucking the stem of the measuring unit too tightly when mounting may damage the spindle and prevent its smooth motion.
- A holder of dimensions as shown in Fig. 2 may be used to mount the measuring unit, tightening the screw to about 4 N·m torque.
- Since mounting parallelism affects the measuring accuracy, adjust the parallelism to within 0.3 mm in relation to 100 mm displacement by means of mount bracket (or sleeve).
- Fix the cable in a suitable position to prevent possible cable breakage. Never handle the cable by forcibly pulling or bending it. (Inside bend radius 50 mm or more)
- If the spindle is to be fixed to the machine, use coupling DZ-191 which is optionally available. Refer to the DZ-191 Instruction Manual regarding the mounting procedure.
- After the stem is secured, do not apply force in the rotational direction. This could cause a failure.

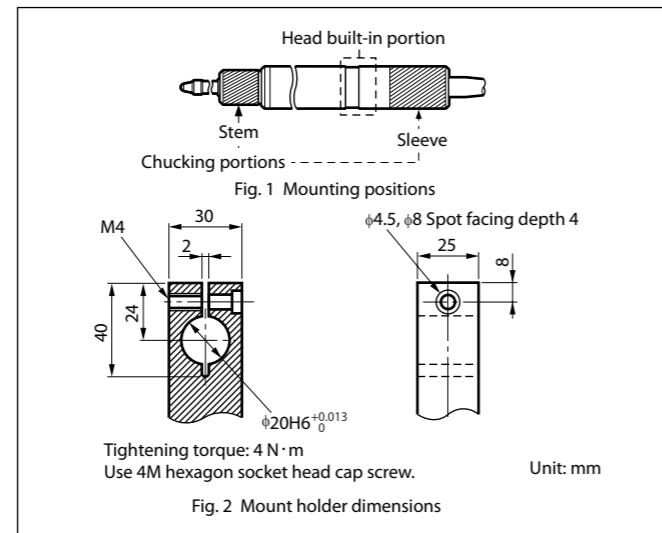

■ Troubleshooting

The operating status of the measuring unit can be checked using the LED indicator.

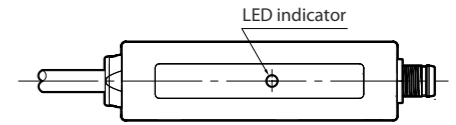

LED lighting color	Details	Remedial action
Lights in blue.	The power is turned on. Normal operation is now performed. The reference point has been detected.	-
Blinks in blue.	The power is turned on. The reference point standby status is established or the reference point is being detected.	When the reference point is used, turn on the power with the spindle extended as far as possible (Note: in case of SV type, with the spindle contracted), and then move the spindle 1.5 mm or more. When the power is turned on with the spindle stopped near the reference point position, it may not be possible to detect the reference point or the reference point may shift.
Blinks in red.	The signal level of the measuring unit is abnormal.	After dealing with the factor suspected to be responsible for the alarm, reset the software or turn the power back on.
Lights in red.	The maximum response speed has been exceeded. The signal level of the measuring unit is abnormal. Serial communication trouble has occurred. Normal operation cannot be performed due to the effects such as external noise etc.	If the same symptoms persist even when the power has been turned back on, the measuring unit might be malfunctioned.
Off	Power OFF	If the same symptoms persist even when the power has been turned on, the measuring unit might be malfunctioned or the cable might be broken.

■ Dimensional Diagrams

* When cable extension is needed, please use CE38 which is optionally available. (Cable length Max. 4 m)

